

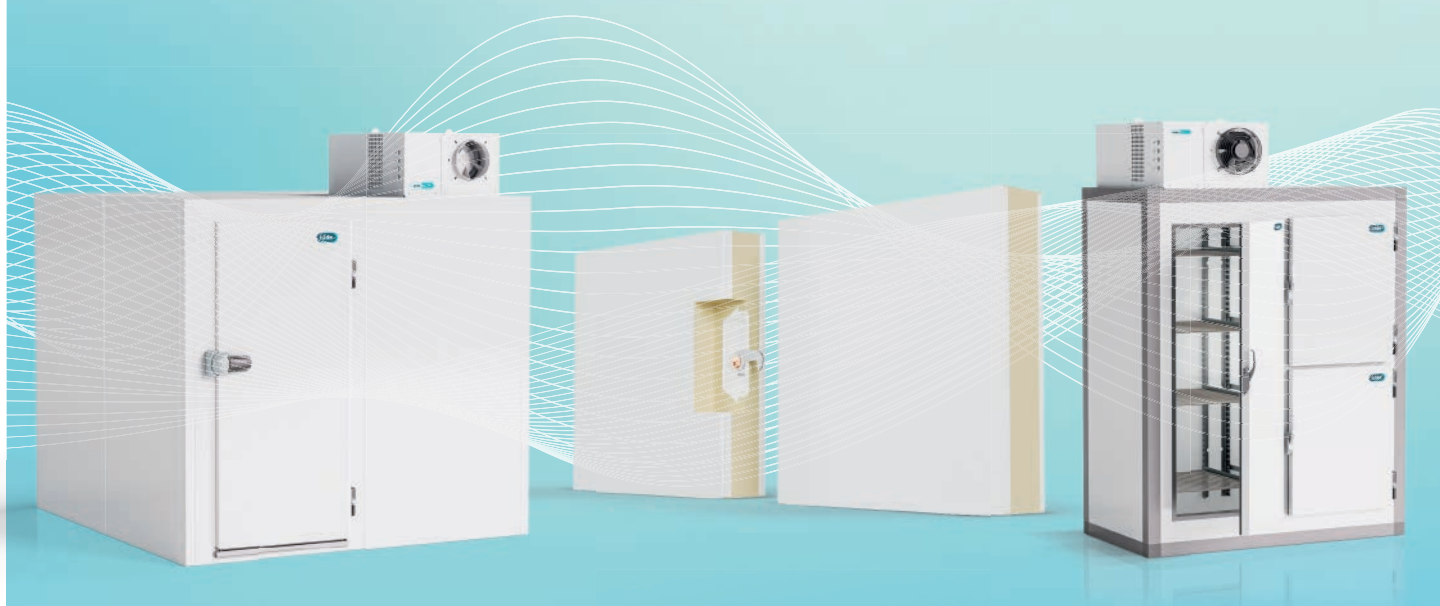

COLD ROOMS

CATALOGUE



2025

High Cooling Performance

IN KIDE WE DESIGN AND MANUFACTURE
COMPREHENSIVE REFRIGERATION
SOLUTIONS FOR OUR CUSTOMERS.



+50

YEARS OF EXPERIENCE
IN THE INDUSTRY

Headquarter
IN BIZKAIA (SPAIN)

100%
MADE IN EUROPE

+ 8000 m²
MANUFACTURING PLANTS

+39 M €
TURNOVER IN 2024

+50%
SALES IN EXPORT MARKET

+180
PROFESSIONALS



Cooperativism is in our DNA



KIDE is a cooperative company integrated in **MONDRAGON Corporation**, the leading Basque industrial group and the 10th biggest business group in Spain. It is a global benchmark for cooperativist work.

We have a unique and differential value proposition in the market



EVEREST
COLD ROOM



UNIVERSAL
COLD ROOM



INDUSTRIAL
COLD PANEL

DOORS

- Cold Room Doors
- Semi Insulated Doors
- Logistic Doors
- Fireproof Cold Room Doors



Hinged



Sliding



Service door



Swing

ACCESORIES



Polyethylene protections



PVC protections

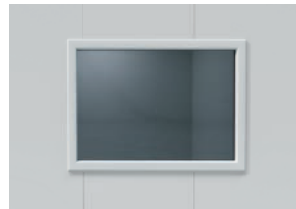

Windows



Sanitary coving



Trims and profiles



Ceiling fastening systems



Alarms



Aluminium and polyethylene shelving

COLD EQUIPMENT



kide BLOCK

Compact wall or ceiling mounted monoblock refrigeration units for small volume cold rooms in medium and low temperature applications.



kide SPLIT

Commercial split refrigeration equipment for small volume cold rooms in medium, low and high temperature applications.



kide WATERLOOP

Waterloop is a commercial cooling system with indirect condensation.



kide PACK

Industrial refrigeration equipment for low, medium and high temperatures



kide CHILLER

Glycol chillers for high, medium and low temperature applications.



kide DRYER

Drying equipment, specialised in emulating the natural drying, curing and maturing processes.

CONFIGURATOR KIDE

CONFIGURE YOUR PROJECTS WITH DISCAFWEB



Index



 **KIDE
EVEREST
COLD ROOM**
P. 8



 **KIDE
UNIVERSAL
COLD ROOM**
P. 12



**KIDE
MODULAR
CABINET**
P. 16



**KIDE
INDUSTRIAL
COLD PANEL**
P. 20

ACCESORIES
P. 24

ANNEX
P. 26

KIDE EVEREST COLD ROOM



By its quick and secure system of joining

The fastening system which KIDE has developed, besides being quick and simple, guarantees perfect adjustment between vertical panels, as well as between vertical and ceiling/floor panels. Due to that, the insulation which the cold room offers is complete, complying with its function with the best results. The KIDE joint system is as simple to loosen as to adjust, which facilitates dismantling the panel quickly in case of need.



PIR
FOAM COLD ROOMS





How is it possible to save up to 20% of the time in the assembly of the panel?

WITH THE NEW CEILING-WALL SUPPORT

KIDE has developed an exclusive system for joining vertical panels with ceiling panels. This system results in important advantages:

- 1 Great ceiling stability:**
The horizontal panel is supported 55 mm on the vertical panel, giving total stability to the ceiling.
- 2 Ease of assembly and dismantling:**
The union system with the joints between the panels goes in vertical sense, allowing the ceiling to be assembled after assembling the vertical panels and to be dismantled without unfastening the joints.
- 3 A perfect aesthetic sense thanks to the invisible joints:**
The vertical panel goes from the floor up to the ceiling in one piece. Its union with the ceiling panel is made through a single joint which, thanks to our exclusive joint system becomes invisible, giving perfect aesthetics.
- 4 Total Insulation:**
All joints, instead of being plane, are in male-female format, which guarantees a perfect adjustment between the panels, obtaining a complete insulation.

BY JOINING THE VERTICAL PANELS

Another advantage in the assembly of the KIDE MODULAR COLD ROOM is the incorporation of vertical corner pieces. Thanks to these panels, situated in each corner of the cold room, all vertical panels have the same design, resulting in a more simple and flexible assembly system.

Besides, the positioning of the door is more flexible than in the cold rooms with different types of panels, allowing to place it wherever you want. Unlike other companies, the KIDE corner pieces are made of the same material as the panels, with the same joint system, making assembly equally easy. Due to that, the exterior part of the cold room remains totally homogeneous.

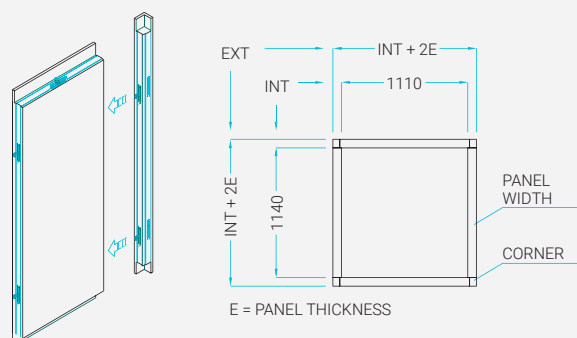

Design at the service of the installer

The KIDE EVEREST MODULAR COLD ROOM, not only facilitates the assembly and dismantling of the cold room and guarantees total insulation, but it also gives an aesthetic sense by hiding the joints.

KIDE EVEREST COLD ROOM

TECHNICAL SPECIFICATIONS

EVEREST KIDE COMMERCIAL COLD ROOMS are made up of prefabricated polyurethane SANDWICH type modular panels.

VERTICAL PANELS

- Width modulation: Module 190 mm.
- Panel widths (mm): 190 / 380 / 570 / 950 / 1,140.
- Cold room height (mm): Customised up to 3,700 internal.
- Thickness (mm): 60 / 75 / 100 / 120 / 150.
- Maximum length (mm): 4,000.

TYPE OF JOINT

- Tongue-and-groove joint with eccentric stainless steel (AISI 430) connection hook and square key. Hook traction force greater than 200 kg. Guarantees the airtightness of the joints.



FINISH

- White lacquered galvanized steel sheet, with peelable protective film. Slightly profiled. White RAL 9010. Food grade quality.
- Coating: polyester paint, 25 microns (including primer). According to EN 10169 standard.
- Smooth finish on request. Check page 26 for other finishes.

INSULATION

- "PIR FOAM" cold rooms.
- Rigid polyurethane foam, neither CFC nor HCFC.
- Density 40 Kg/m³ (tolerance +3 -0 Kg/m³).

Panel thickness in mm.	60	75	100	120	150
U(W/m ² °C)	0.38	0.31	0.23	0.19	0.15

FLOORS

- **S8 Pedestrian flooring.**
Interior finish in 1 mm thick anti-slip plastic-coated sheet metal. Food grade quality. For pedestrian use only.
Static load: 2,000 kg/m² evenly distributed.
Dynamic load: **No rolling load.** For pedestrian use only.
Slip resistance: R10.
- **Reinforced flooring-M9.**
Reinforced interior finish in 9 mm birch plywood with non-slip phenolic resin. For pedestrian and manual trolley traffic.
Static load: 4,000 kg/m² evenly distributed.
Dynamic load: 400 kg on 4 **non-metallic** wheels.
Slip resistance: R11
- Check page 26 for **other flooring options.**

INSULATED DOOR

- Hinged door measuring 0.9 x 1.9 metres, assembled on a vertical panel, with the same finish as the panel and stainless steel screws. Other sizes and finishes available to order.
- In freezer rooms, heating resistance at 220 V.
- Other door options available to order.

INCLUDED ACCESSORIES

- **Vertical sanitary profile** on the interior, ceiling, and floor in all models.
- **Pressure balance valve** in freezing (100 mm panel rooms).
- **"U" floor profile** in rooms without floor.

ASSEMBLY INSTRUCTIONS

1ST STAGE:

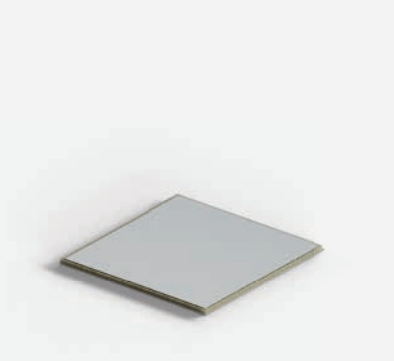

2ND STAGE:



3RD STAGE:



4TH STAGE:

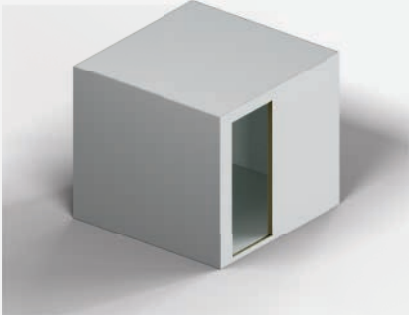

5TH STAGE:



**WHEN PLACING AN ORDER
IT IS VERY IMPORTANT TO
REMEMBER THE MODULE
SYSTEM OF THE COLD ROOMS**

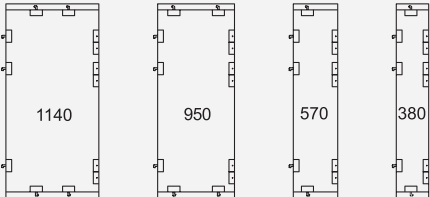

 **SEE VIDEO
ASSEMBLY**

KIDE UNIVERSAL COLD ROOM



Express Service

Speed at KIDE is an ongoing commitment, speed of cold room assembly and, it goes without saying, speed of delivery. Our Express Service guarantees your UNIVERSAL MODULAR COLD ROOM will be manufactured in just 48 hours*.

* Leaves factory on the second working day after date of order.



Easily expandable

It is really easy to expand the size of a pre-installed cold room in both directions. A minimum amount of panel references provides a maximum number of modular cold rooms.



Ideal for stock

By unifying the panel shapes, they are packaged in a more compact form, which facilitates their transport and handling. In addition, because the number of references has been reduced you can optimize the stock available at your warehouse.



Easier assembly

Cold room assembly has been made simpler by unifying the wall and ceiling panel design, making them interchangeable.



Fully interchangeable panels

Any panel can be used for a wall or ceiling, as they all incorporate an exclusive system whereby can be assembled in any position.



TECHNICAL SPECIFICATIONS

The UNIVERSAL MODULAR ROOM is made up of prefabricated modular high-density injected polyurethane SANDWICH panels with a range of thicknesses that adapts to different insulation needs.

VERTICAL PANELS

- Width modulation: Module 200 mm.
- Panel widths (mm): 400 / 800 / 1,000 / 1,200.
- Cold room height (mm): Customised up to 3,200 internal.
- Thickness (mm): 60 / 80 / 100.
- Maximum length (mm): 4,000.

TYPE OF JOINT

- Eccentric joint hook with hexagonal key. Guarantees the tightness of the joints.



FINISH

- White lacquered galvanized steel sheet, with peelable protective film. Slightly profiled. White RAL 9010. Food grade quality.
- Coating: polyester paint, 25 microns (including primer). According to EN 10169 standard.
- Smooth finish on request. Check page 26 for other finishes.

INSULATION

- "PIR FOAM" cold rooms.
- Rigid polyurethane foam, neither CFC nor HCFC.
- Density 40 Kg/m³ (tolerance +3 -0 Kg/m³).

Panel thickness in mm.	60	80	100
U(W/m ² °C)	0.38	0.28	0.23

FLOORS

- **S8 Pedestrian flooring.**
Interior finish in 1 mm thick anti-slip plastic-coated sheet metal. Food grade quality. For pedestrian use only.
Static load: 2,000 kg/m² evenly distributed.
Dynamic load: **No rolling load.** For pedestrian use only.
Slip resistance: R10.
- **Reinforced flooring-M9.**
Reinforced interior finish in 9 mm birch plywood with non-slip phenolic resin. For pedestrian and manual trolley traffic.
Static load: 4,000 kg/m² evenly distributed.
Dynamic load: 400 kg on 4 **non-metallic** wheels.
Slip resistance: R11
- Check page 26 for **other flooring options.**

INSULATED DOOR

- Hinged door measuring 0.8 x 1.9 metres, assembled on a vertical panel, with the same finish as the panel and stainless steel screws. Other sizes and finishes available to order.
- In freezer rooms, heating resistance at 220 V.
- Other door options available to order.

INCLUDED ACCESSORIES

- **Vertical sanitary profile** on the interior, ceiling, and floor in all models.
- **Pressure balance valve** in freezing (100 mm panel rooms).
- **"U" floor profile** in rooms without floor.

KIDE UNIVERSAL COLD ROOM

ASSEMBLY INSTRUCTIONS

1ST STAGE:

Assembly the floor panels. Then, fix the corners and adjust the covers. The floor should be completely flat.

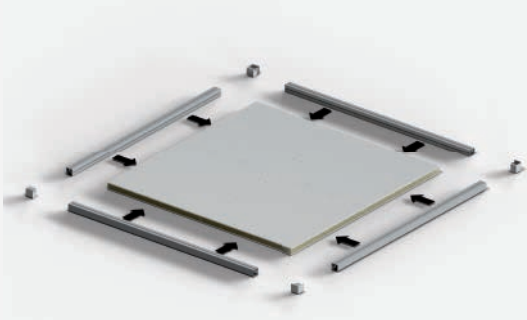

If the cold room has no floor, the ground of the cold room perimeter must be completely levelled width (E+150 mm). Fig A.

Fig A.

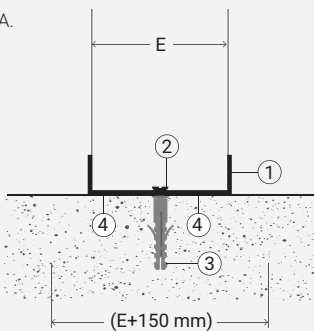

- ① U PVC profile
- ② Screw
- ③ Nylon plug
- ④ Polyurethane sealant

2ND STAGE:

Assembly the corners to the vertical panel and follow assembly the vertical panel.



4TH STAGE:

Assembly the ceiling panels.



3RD STAGE:

Finish the assembly of the vertical panels, put the upper corners.



5TH STAGE:

Place the last corner and adjust the covers.

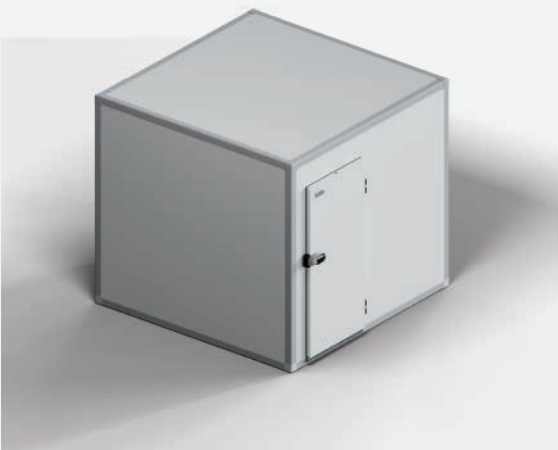

**SEE VIDEO
ASSEMBLY**

KIDE MODULAR CABINET



Full solution

Complete solution that includes: cold room, refrigeration equipment and set of trays and rack holders.

KIDE modular cabinets are a full solution for storage of products at low or medium temperature.



Easier assembly

By standardizing the panel shapes, the assembly of the modular cabinet is facilitated, as the panels are interchangeable with each other.



Interchangeable panels of injected polyurethane

Any panel can be used either on the wall or on the ceiling, as they all have a unique system that allows them to be mounted in any orientation.



Easily expandable

Extending the dimensions of an already installed modular cabinet is very simple, both in one direction and in the other.



TECHNICAL SPECIFICATIONS

INSULATION THICKNESS

- "PIR FOAM" cold rooms.
- Rigid polyurethane foam without CFCs or HCFCs. Density: 40 kg/m³ (+3 -0kg/m³).
- Panel thickness: 80 mm.

TYPE OF JOINT

- Eccentric joint hook with Allen key.

COATING

- Galvanised steel. Lacquer: polyester paint, 25 microns. Including primer.
- Compliant to EN 10169.
- White colour RAL 9010 and foodsafe with peelable protection film.
- Smooth internal and external finishing.

INSULATED DOOR

- Small hinged hatch of 605 x 800 mm per loop (2 units).
- Large hinged door of 605 x 1700 mm per loop (1 unit).

LOW TEMPERATURE

- When the cabinet is used at low temperature, the doors are provided with an electrical resistance on the door frame and a pressure balance valve.

REFRIGERATOR EQUIPMENT

- Kide compact roof mounted unit.

TRAY-HOLDER SET

- A standard tray-holder set is included for trays with dimensions of 600 x 400, made of stainless steel, per loop. Each set consists of four adjustable feet each 70 mm, four sets of guides (2 units/set) and eight epoxy grids



KIDE MODULAR CABINET

1 OPENING

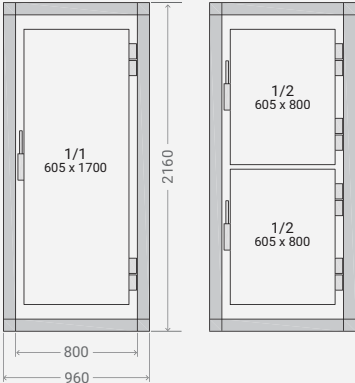

2 OPENINGS

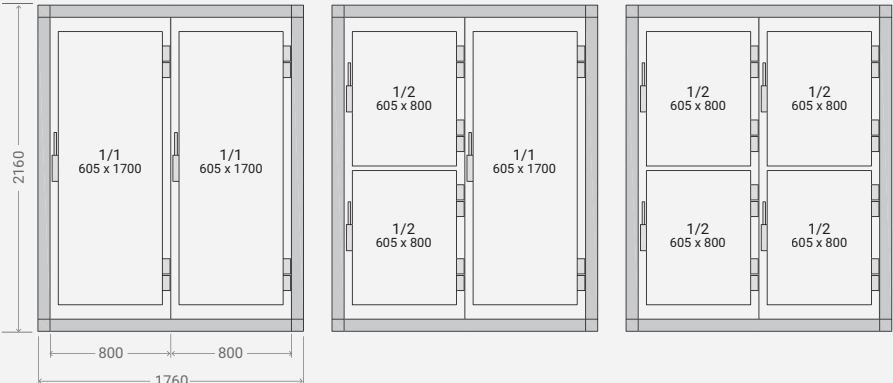

3 OPENINGS

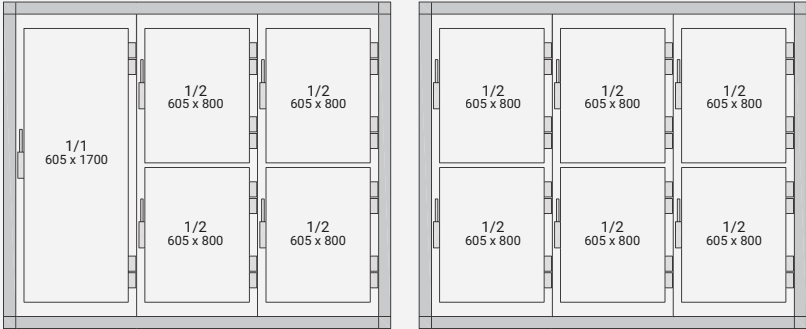
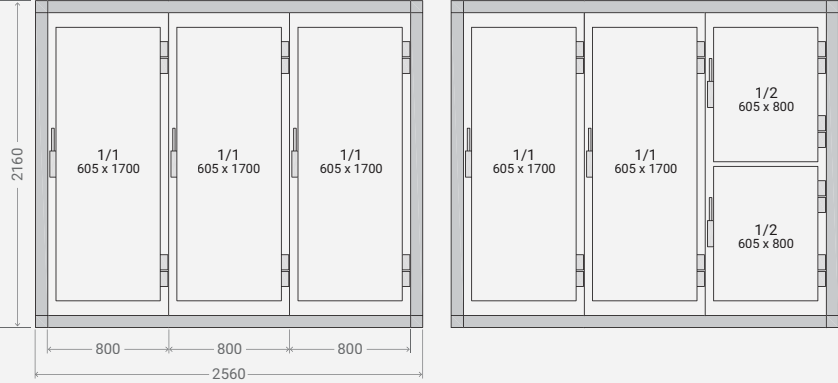

4 OPENINGS

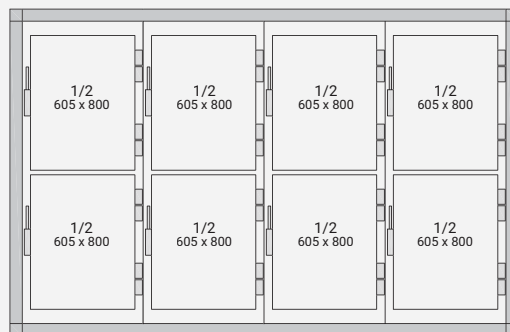
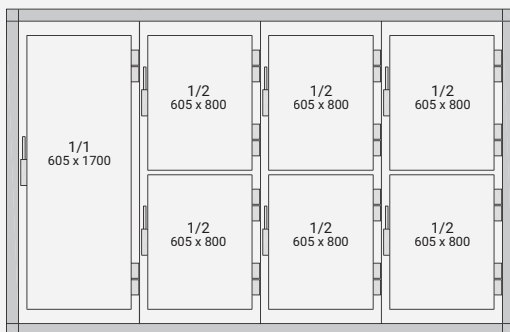
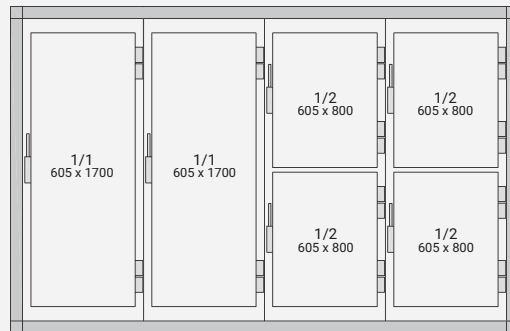
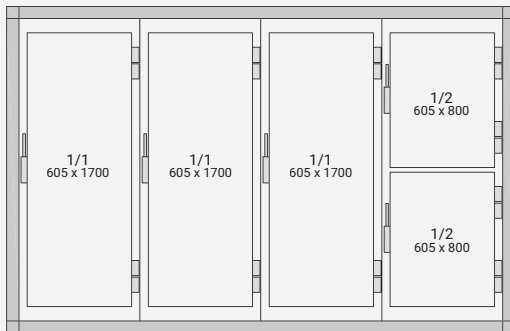
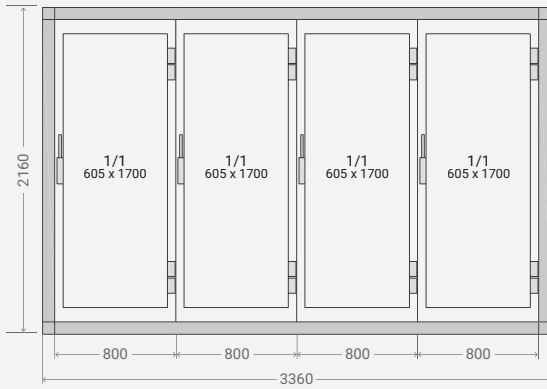

KIDE INDUSTRIAL COLD PANEL



PANEL PIR BS1D0 WITH STAINLESS CAMLOCK



Union is strength and so is the insulation

KIDE has developed a double male female system which is reinforced by stainless steel cam locks. Kide cam locks have AISI 430 hook unlike polyamide hooks used commonly. This hook does not elongate and hence pulls the panels together ensuring a perfect seal.

The cam lock housing is made from high quality rigid PVC. The loops in the housing ensure a firm anchor in the foam, increasing considerably the pull out strength. Kide panel joints are better by design, providing total insulation and impermeable joint, which results in important energy savings day after day.

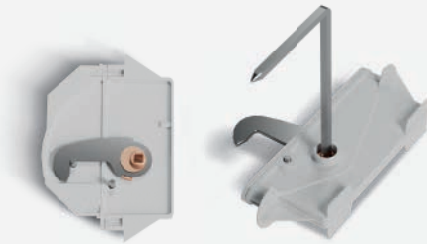

A system that attracts



KIDE double male-female joint: perfect for total insulation.



The KIDE INDUSTRIAL REFRIGERATION PANEL guarantees the maximum insulation in all kind of industrial cold rooms. It can be manufactured up to a length of 12 m and 200 mm thickness, which reduces the number of joints in the walls and ensures a high insulation for any cold room size.



Easy to assemble and dismantle

The integrity of the joint between insulated panels determines the insulation properties of the cold room as a whole. KIDE panels are joined using cam locks with stainless steel AISI430 hooks, which not only provide structural strength, but also pull and retain the panels together ensuring an excellent insulation as well as a perfect aesthetic.

This fastening system requires only 3/4th of a turn for a quick and perfectly aligned joint. Thanks to its easy assembly, a substantial reduction in assembly time results in saving both, time and money.



Manufacturing in discontinuous form brings continuous advantages

- Production flexibility: in terms of delivery times, sizes, thicknesses, finishes and other specific requirements.
- Stainless Steel camlock available.
- Factory-made thermal break cut and rebate cut.
- Instant replacement of any panel in case of damage during installation.
- Faster and more economical installation.
- Complete project design with detailed drawing.
- Supply of all necessary accessories for assembly.



KIDE INDUSTRIAL COLD PANEL

TECHNICAL SPECIFICATIONS

The KIDE SANDWICH panel has the CE marking according to the European standard EN14509.

INSULATION

- Rigid polyurethane foam, neither CFC nor HCFC.
- Density 40 Kg/m³ (tolerance +3 -0 Kg/m³).
- Average COEFFICIENT OF THERMAL TRANSMISSION "U".

Panel Thickness in mm.	60	80	100	120	150	180	200
U(W/m ² °C)	0.38	0.29	0.23	0.19	0.15	0.13	0.12
Panel weight Kg./m ² coating, 2 faces, sheet 0.5 mm.	11	12	13	14	15	17	18

REACTION TO FIRE

- Panel PIR BS1D0 (according to EN13501-1).
- Panel PUR BS2d0 (according to EN13501-1).
- Working Range: Between -40 °C and +75 °C according to thickness.

COATING

- STANDARD:
Steel Sheet slightly ribbed, galvanized and pre-lacquered polyester (25 µ) with a peelable protective film.
White colour, RAL 9010. Food safe qualify.
- THROUGH ORDER:
Stainless Steel sheet.
Steel sheet plastified with food quality PVC, 120 µ.
Other steel sheet thicknesses and finishes.

FASTENING SYSTEM

- Double male-female format with stainless steel AISI430 cam locks. A square key is used to turn the hook on a metal axle. The eccentric movement of the hook pulls the two panels together ensuring a perfect joint.
- Highest insulation of the joint:
AIRTIGHTNESS = "O" at 50 Pa (EN-12114)
WATERPROOFNESS = "A" at 1200 Pa (EN-12865)



Panel BS1d0 with stainless CAMLOCK

FLOOR AND CEILING PANELS

- Length: Maximum of 12,000 mm.
- Width: Usable 1,180 mm.
Total width 1,195 mm.
For sea container: 1,100 mm
- Thickness: 60, 80, 100, 120, 150, 180, 200 mm.
- Tolerances: According to standard EN 14509.

Admissible load per panel with three supports and deflection of $l/200$, being l the distance between supports.

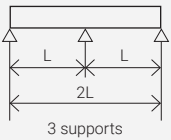

- e = 60 mm
- e = 80 mm
- e = 100 mm
- e = 120 mm
- e = 150 mm
- e = 180 mm
- e = 200 mm

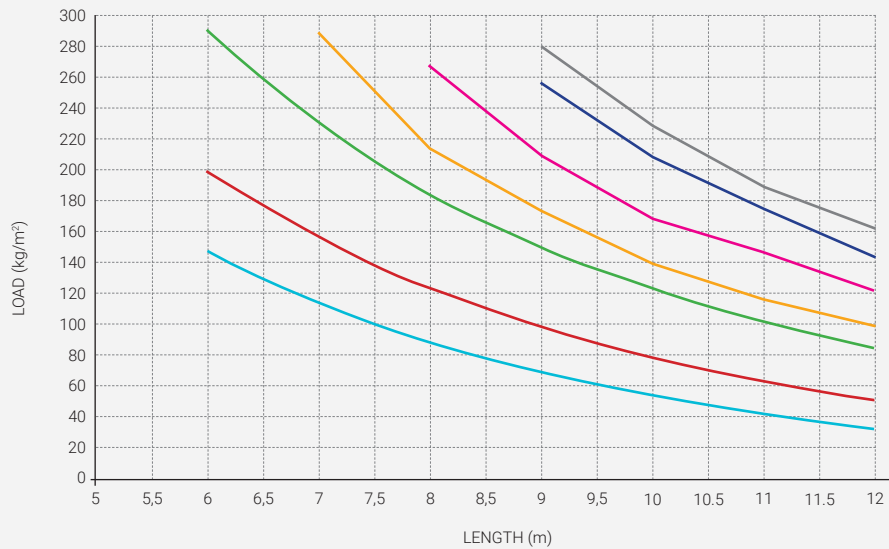

Admissible load per panel with two supports and deflection of $l/200$, being l the distance between supports.



- e = 60 mm
- e = 80 mm
- e = 100 mm
- e = 120 mm
- e = 150 mm
- e = 180 mm
- e = 200 mm

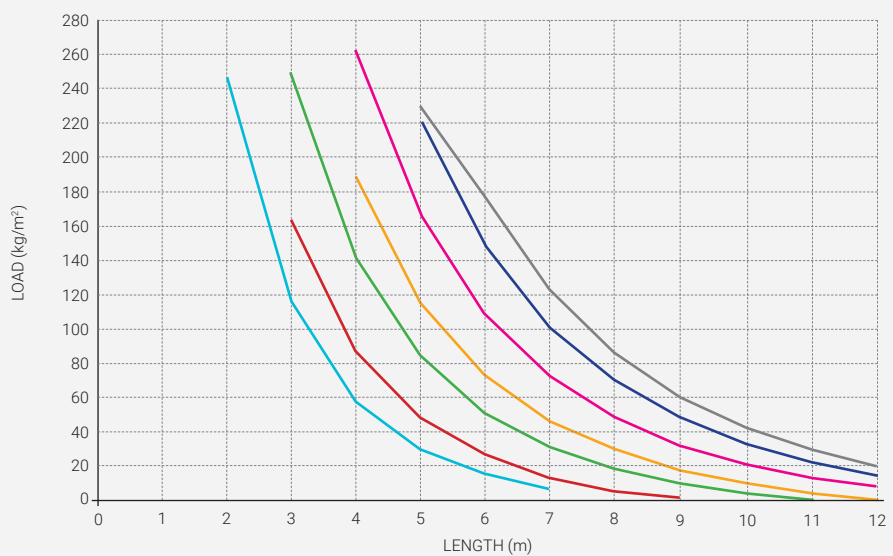

Admissible loads for these panels according to thickness, deflection $L/200$ and standard NBE 95.

The safety coefficient is 1.7. So, according to this standard, the load combinations SHOULD NOT be exceeded.

ACCESORIES

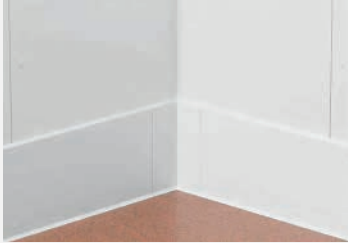

POLYETHYLENE PROTECTIONS

USE

To protect the panel, extending its lifetime. Made of high density, unbreakable polyethylene.

ADVANTAGES

High impact and scratch resistance.
Two-piece system.
Floor and wall mounting.
Hidden screws.
Hygienic and easy to clean.
Quick and easy to assemble.
Skirting boards available in heights 150, 210, 300 and 500 mm.
Handrail available in 150 mm.

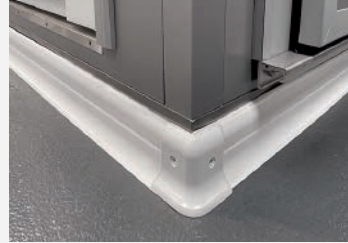

PVC PROTECTIONS

USE

Protector for the panel, extending its useful life. Made of PVC.

ADVANTAGES

Impact and scratch resistant.
Easy to install.
Hidden fastening screws.
Hygienic and easy to clean.
Corner finishing pieces.
Protector height 100 mm.



WINDOWS

USE

It makes it possible to see the activity that takes place within a room. Suitable for positive temperature positive temperature.

ADVANTAGES

White lacquered aluminium frame with thermal break.
Counterframe adapted to the thickness required.
Lamiglass 4/12/4 system glass.
12 mm inner air gap.
Quick and easy installation.



PRESSURE VALVE

USE

Element to balance the pressure differences between the inside and outside of the cold room. Equipped with heating element. Different models depending on the needs. Wall or ceiling application.



SANITARY COVING

USE

Instalación en juntas entre suelo-vertical, vertical-vertical y vertical-techo.

Evita la acumulación de la suciedad y facilita la limpieza de las esquinas del recinto.

ADVANTAGES

Aluminum or PVC base.

Flexible lips for perfect fit.

Snap-fit system, allowing for easy installation.

Complies with sanitary regulations.

Available with LED light.



TRIMS AND PROFILES

USE

Profiles of all types of geometry, used for the installation of cold rooms.

3000 mm long profiles.

Standard white lacquered steel finish.

Multiple finishes available. Stainless steel. AISI 304, PVC...

Same finish as the cold room:

- Standard: white lacquered RAL 9010
- Options: Stainless steel, PVC, PET...

All profiles covered with protective film.



CEILING FASTENING SYSTEMS

USE

Profiles for suspending cold room ceilings.

4,000 mm lacquered aluminium profiles (length per piece).

For positive and negative temperature applications.

Suspension with stainless steel rod and bracket.



ALARMS

USE

Adapted to different types and applications of cold rooms.

Suitable for all types of products. Perishable, packaged, etc.

Equipped with alarm systems, man-locked, thermometer, hygrometer, leak detector...

Temperature logging and data monitoring option.



ALUMINIUM AND POLYETHYLENE SHELVING

USE

Shelving units with an anodised aluminium frame with foodgrade polyethylene grid shelves.

Perfectly suitable for use in cold rooms and under the most demanding health requirements.

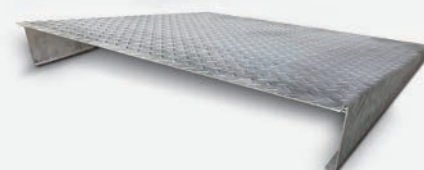

RAMP

USE

They are designed to facilitate the access for carts, trolleys, and any wheeled transport equipment to a cold room that has an elevated floor.

Built with a metal iron structure and stainless steel sheet, available in various sizes.

ANNEX

SAMPLE OF FINISHES

VERTICAL- CEILING

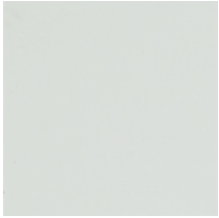

* LAC 9010



* PVC (S5)

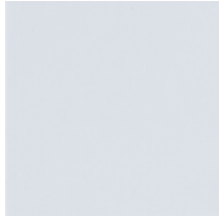

* PET (K5)



* STAINLESS STEEL (I6)

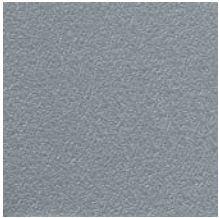

* PVC (C5)



* LAC SILVER (Q5)



* LAC BLUE (E5)



* LAC BLACK (L5)

FLOOR



PVC (S8)



PLYWOOD (M9)



GALVA (G2)

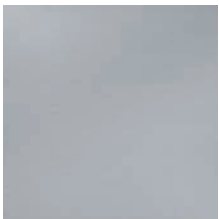

STAINLESS STEEL (I2)



STAINLESS STEEL (I8)

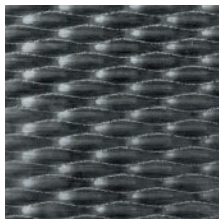

STAINLESS STEEL (A8)

REINFORCEMENTS



GALVA 3/5mm (G3)

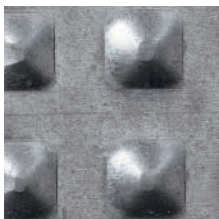

GALVA 2/4mm (L3)

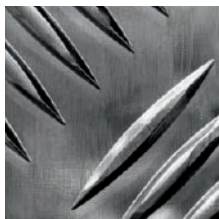

ALU 2/4mm (A2)



ALU 3/5mm (A3)

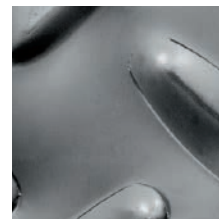

STAINLESS STEEL (R2)

SUGGESTIONS

COLD ROOM FLOOR RESISTANCES

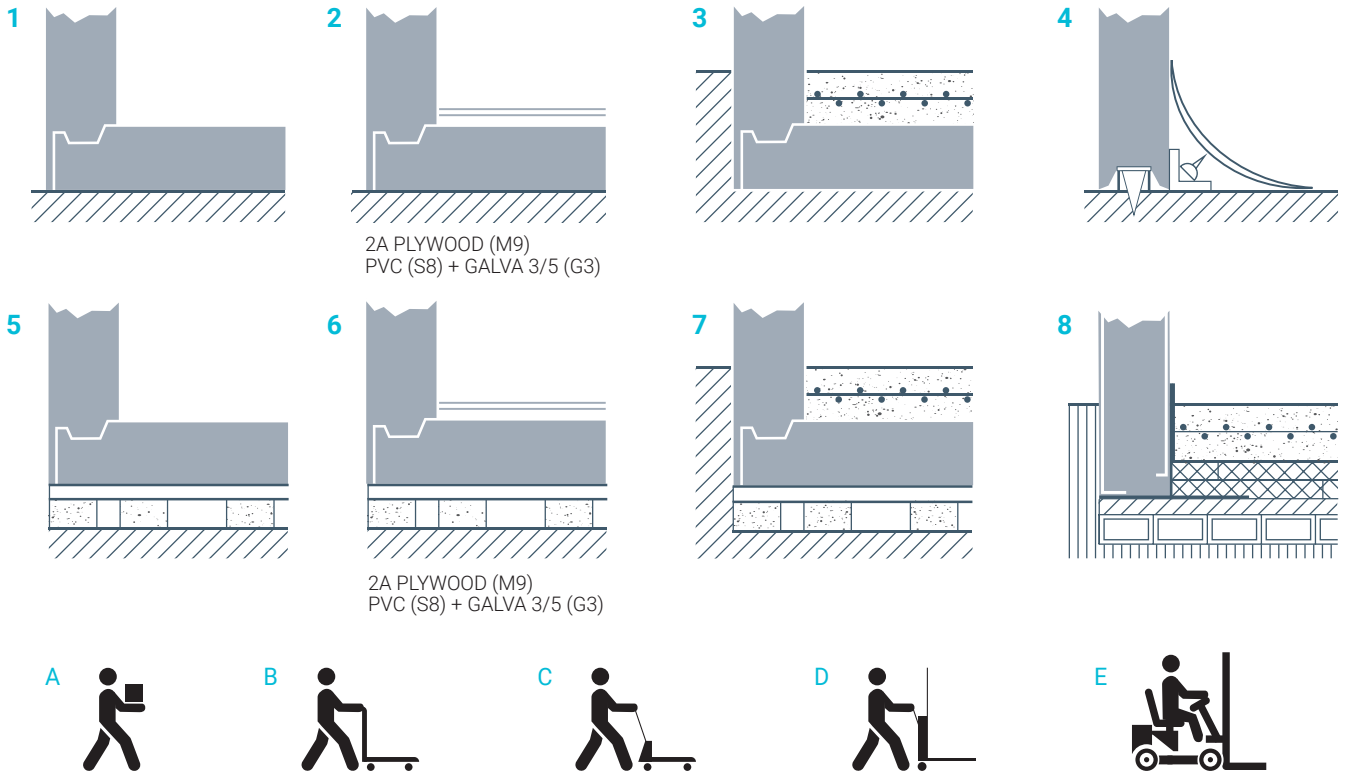

The floor where the cold room is mounted should be completely levelled.

CASES	1	2A	2B	3	4	5	6A	6B	7	8
Maintenance method	A	A B	A B C D	A B C D E	A B C D E	A	A B C	A B C	A B C D E	A B C D E
Temperature Limit	-5	-5	-5	-5	0	-40	-40	-40	-40	-40
Static Load Kg/m ² uniformly spread	2 000	4 000	6 000	C E M E N T	C E M E N T	1 000	1 500	1 500	C E M E N T	C E M E N T
Dynamic Load on 4 wheels in Kg	NO	400	1 000			NO	400	400		
	PVC (S8) // SS (A8)	PLYWOOD (M9)	PVS (S8) / PLYWOOD (M9) + GALVA 3/5 (G3)	C E M E N T	C E M E N T	PVC (S8) // SS (A8)	PLYWOOD (M9)	PVS (S8) / PLYWOOD (M9) + GALVA 3/5 (G3)	C E M E N T	C E M E N T

SUPPORT ON VENTILATION DUCTS

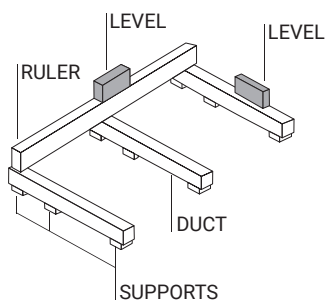

MULTIPLE ROOFS

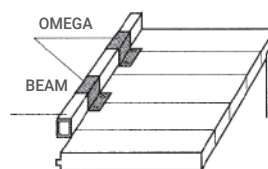

On the transversal joints, the panels will be supported or hung according to the characteristics of the place where the cold room is installed.

Note

A series of horizontal dotted lines spanning the width of the page, intended for handwritten notes.

EXCLUSIONS

- Any material or work required and not specified in this offer.
- Licences, visas and permits, safety study and safety coordinator.
- Cold room project.
- All transfers at a level other than road level or over distances of more than 20 m. that cannot be carried out by forklift will be subject to a surcharge that will be invoiced.
- Reception and location of equipment at the established sites.
- Cranes and necessary loading and unloading equipment.
- Removal of surplus material (remaining panels, etc.).
- Masonry, carpentry or plumbing works, such as levelling, pipes, drains, power supply, water drainage, support points, etc.
- Sealing between civil floor and panel.
- Sealing of joints between panels with silicone.
- Finishing of the existing gaps between the cold room and the masonry walls.
- Panel cuts for other trades.
- General cold room assembly (pipes, valves and fittings for interconnection between elements) and replenishment of refrigerant and oil, as well as ducts and their assembly.
- Lighting and light fittings.
- Half-round profiles, stainless steel or civil works (in the case of dryers), to favour the correct distribution of air between the product.
- Electrical connections. The customer shall provide adequate electrical connections for the tools necessary to assemble the cold room and equipment, as well as for their operation. 220 V 20 kW electrical connections.
- Resistor/valve/alarm connection
- Protected low-voltage connection to the equipment's electrical panel.
- Wiring between equipment, probes and control panels, as well as computer if necessary.
- Ethernet (level 1) cabling between the PLCs of the controllers and the supervisory PC.
- Appropriate means of handling, lifting, clearing of debris. These shall be provided by the customer.
- Any additional movement for reasons beyond KIDE's control (unprepared assembly area, installation of sanitary fittings, adjustment of doors after floor preparation, etc.) will be invoiced separately.
- The valuation has been carried out according to drawings or measurements provided by the customer/engineering. Any work not specified in the plans, such as lining columns, having to make cuts as a result of erroneous measurements, ramps, access covers, etc., will be invoiced separately.

PRODUCT LIABILITY

- KIDE shall be liable for any harm to persons or property resulting from defects or errors in the products and/or services delivered by KIDE (with the exceptions set out in these General Terms and Conditions). However, KIDE does not, under any circumstances, assume liability for loss of operation, loss of time, loss of earnings or similar indirect loss of the Buyer.
- In relation to the above point, under no circumstances shall KIDE assume liability for operational losses, loss of profit or any other type of indirect damage.

GENERAL CONDITIONS OF SALE

- The order will be processed if and only if it is accepted by the insurance company or credit institution and provided that there is no outstanding balance with KIDE.
- In the case of orders that include transport, if there are difficulties for delivery by normal lorry in areas that are difficult to access, the customer must indicate this when placing the order. This special transport will be invoiced separately and a 6% surcharge will be applied to the value of the goods.
- The delivery period shall commence after written confirmation of the order, acceptance of the order and formalisation of the payment terms (receipt of the advance payment, notification of the letter of credit, etc.).
- The deadline is considered as material packed and ready for delivery.
- In the event of public holidays (Easter, Christmas, summer), the period for dispatch may be increased accordingly, and confirmation is therefore recommended.
- In the case of payment by letter of credit, this shall be irrevocable and confirmed, and opened in a first class bank (BBVA, SABADELL, SANTANDER, LABORAL KUTXA, BANKINTER, BANKIA).
- The duration of the credit shall be at least 1 month longer than the agreed delivery period. KIDE is under no obligation to commence the manufacture of the goods or to provide the services until the letter of credit has been confirmed and accepted by KIDE.
- KIDE's registered office and its premises shall be the place of performance of the contractual obligations. The obligations shall be deemed to have been fulfilled by KIDE when it notifies the Customer that the goods have been made available at the facilities of the manufacturer's registered office. Ownership of the manufactured goods shall only be transferred when payment has been made in full, however, the risk of loss and/or damage shall be transferred as soon as the goods have been made available at the place of fulfilment of the contractual obligations.
- In the event that within 15 days of KIDE making the goods and/or services available to the Customer, the latter does not indicate a place for delivery of the goods and/or services or does not take delivery of the material and/or services, KIDE reserves the right to terminate the contract early, to destroy the material at the Customer's expense and to claim from said Customer the costs of scrapping and/or temporary storage, losses due to resale to third parties and any other damages arising from such situation, and shall be entitled to deduct these damages from the amount paid in advance by the Customer.
- Alternatively, KIDE reserves the right to store the goods manufactured in its facilities or in the facilities of a third party, and may claim a financial penalty of 15 euros per m²/month for such storage, without prejudice to KIDE's right to claim for damages and losses incurred as a result of the situation. The aforementioned storage period may be extended for a maximum of 45 days. Once this period has elapsed, KIDE may terminate the Contract without prejudice to its right to claim all damages and losses that it may have incurred.
- If payment is not made on the due date, KIDE will add the financial cost corresponding to the delay in payment. Any delay in payment, for whatever reason, shall automatically increase the price by the interest set in accordance with Law 3/2004 of 29 December on the prevention of late payment in commercial transactions. If it is necessary to resort to legal proceedings for collection, the amount of the debt claimed shall be increased by the costs incurred in its recovery, which will

be subject to a penalty clause of no less than 15% of the debt, all without prejudice to KIDE's right to claim any damages caused by the customer's non-compliance.

- The non-payment of a debt on its due date shall automatically result in early termination and the payment of the entire remaining balance due, as well as the precautionary suspension of deliveries and works.
- KIDE guarantees its equipment against all material and manufacturing defects for a period of 12 months from delivery or a maximum of 14 months from the date it is made available. This warranty obligation consists EXCLUSIVELY of the replacement of the part of the product recognised as being defective, and does not include: transport, refrigerant, installation, assembly or disassembly costs, nor any damages that may have been caused.
- The product delivered in replacement of the defective product shall be guaranteed under the same terms and conditions applicable to the replaced product and for the remaining period of the warranty.
- The warranty shall only apply if the equipment has been transported, stored and handled in accordance with KIDE's instructions, has not been mistreated or damaged by accident or negligence of the customer or third parties, and has been operated only by KIDE's own personnel or personnel authorised by KIDE.
- KIDE's liability for all claims arising from an order is limited to the total amount of the order. The customer waives any further claims for damages.
- The replaced material shall become the property of KIDE unless its destruction is authorised. In the event of an express request for its return, this will be carried out within a maximum of 15 days. In such a case, KIDE shall bear the costs arising from the return and/or delivery of the defective material.
- Other expenses, such as those arising from the travel of technical personnel or labour, are not included and shall be borne by the customer.
- KIDE also guarantees the availability of spare parts, either of the components concerned or of the functional parts into which they are integrated, for a period of 5 years.
- In order to guarantee the quality of the equipment supplied and prior to delivery of such equipment, KIDE S. Coop accepts inspection at its facilities by a specialised laboratory with the costs derived from this inspection being borne by the customer.
- In no event shall KIDE be liable for indirect damages caused to the Customer or any third party for operating losses, loss of sales, revenue or interruption to business or services, loss of profits or other indirect, intangible, non-economic or consequential losses or for losses of a similar kind.
- When the ASSEMBLY service is contracted, it shall be guaranteed for FIFTEEN DAYS from the date of completion of the assembly.
- In the case of marketed products not manufactured by KIDE, the warranty of the manufacturer of said products shall subsist, under the conditions established by the manufacturer, which KIDE shall pass on to the customer.
- The buyer shall hold KIDE harmless from any claims received from third parties for any cause other than a manufacturing defect of the products, as well as from all expenses incurred in the defence against such claims.
- The Buyer is obliged to inspect the products upon receipt. KIDE shall not be liable for any apparent defects once the goods have been

received if they are not checked and the delivery note is not signed as compliant, or if the appropriate complaint is not made within 24 hours.

Likewise, the Buyer shall be obliged to check the measurement and thickness specifications upon receipt of the material delivered by KIDE and, by virtue of this, the Buyer thereby waives any type of claim on the aforementioned specifications if it has already proceeded with the transformation, placement or arrangement of the delivered material. In the event of claims regarding deviations between the quality of the material agreed between KIDE and the Buyer and the quality of the material actually delivered, they shall only be admissible when the quality defect is certified by the Buyer. In the event that the reason for any damage to the material is due to misuse or improper application of the product by the Buyer, the Buyer shall be exclusively responsible for such damage.

In any case, KIDE shall not be liable for:

- Damage to the coating of the material caused by moisture or other contamination detrimental to the coating resulting from improper storage of such material by the Buyer. Furthermore, the same shall apply in the event that the material is damaged during transport, handling, installation and assembly at the Buyer's premises and/or by any other act of negligence attributable to the Buyer or to third parties other than KIDE.
- Damage to the material caused by the cutting of the panels on site by the Buyer or by a third party other than KIDE, which may lead to a modification of the technical characteristics of the material and affect its performance.
- Damage to the material caused by water or by any corrosive product once it has left KIDE.
- Appearance of pockets or 'blistering' in the sandwich panel, as well as any other type of aesthetic defects that do not affect the functionality of the KIDE materials delivered to the Buyer.
- The Buyer undertakes to sign the delivery note for the material and/or the acceptance certificate for the installations once it has been received. In any event, the material shall be deemed to have been accepted without reservation from the moment it begins to be used.
- In the resolution of any question or dispute which may exist between the parties regarding the validity, interpretation, execution and/or termination of the contract, the parties shall be subject to the exclusive jurisdiction of the Courts and Tribunals corresponding to the registered offices of KIDE. This Contract is subject to Spanish law.

Note: KIDE is not responsible for any errors or misinterpretations of the information contained in the catalogue or price list. It also reserves the right to modify the data and values contained therein without prior notice. Such data does not constitute a contractual guarantee.

KIDE, S.Coop. Ltda. Official Reg. of Coop. of the Min. of Lab. No. 20750 - Reg. of Cooperatives of the Basque Government no. VI-215119/86 Tax ID (NIF): F-48071377

kide

HEADQUARTER

Polígono Gardotza, 1
48710 BERRIATUA
Bizkaia (Spain)

Tel: +34 94 603 62 00

e-mail: kide@kide.com
www.kide.com

